

This article was downloaded by: [Pennsylvania State University]
On: 03 June 2013, At: 17:30
Publisher: Taylor & Francis
Informa Ltd Registered in England and Wales Registered Number: 1072954
Registered office: Mortimer House, 37-41 Mortimer Street, London W1T 3JH,
UK

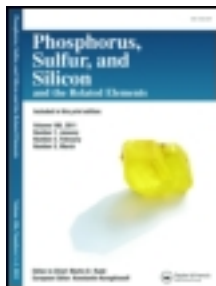

Phosphorus, Sulfur, and Silicon and the Related Elements

Publication details, including instructions for authors and subscription information:

<http://www.tandfonline.com/loi/gpss20>

Preparation of 2,3,4-Trihydroxybutylarsonic Acid: A Starting Compound for Novel Arsonolipids

Maria A. Lala^a, Gerasimos M. Tsvigoulis^a & Panayiotis V. Ioannou^a

^a Department of Chemistry, University of Patras, Patras, Greece

Published online: 03 Dec 2007.

To cite this article: Maria A. Lala, Gerasimos M. Tsvigoulis & Panayiotis V. Ioannou (2007): Preparation of 2,3,4-Trihydroxybutylarsonic Acid: A Starting Compound for Novel Arsonolipids, *Phosphorus, Sulfur, and Silicon and the Related Elements*, 182:12, 2747-2760

To link to this article: <http://dx.doi.org/10.1080/10426500701506184>

PLEASE SCROLL DOWN FOR ARTICLE

Full terms and conditions of use: <http://www.tandfonline.com/page/terms-and-conditions>

This article may be used for research, teaching, and private study purposes. Any substantial or systematic reproduction, redistribution, reselling, loan, sub-licensing, systematic supply, or distribution in any form to anyone is expressly forbidden.

The publisher does not give any warranty express or implied or make any representation that the contents will be complete or accurate or up to date. The accuracy of any instructions, formulae, and drug doses should be

independently verified with primary sources. The publisher shall not be liable for any loss, actions, claims, proceedings, demand, or costs or damages whatsoever or howsoever caused arising directly or indirectly in connection with or arising out of the use of this material.

Preparation of 2,3,4-Trihydroxybutylarsonic Acid: A Starting Compound for Novel Arsonolipids

Maria A. Lala
Gerasimos M. Tsivgoulis
Panayiotis V. Ioannou

Department of Chemistry, University of Patras, Patras, Greece

Possible routes for the preparation of 2,3,4-trihydroxybutylarsonic acid, a key compound for the synthesis of novel arsonolipids, were experimentally evaluated. The best substrate was found to be 3,4-epoxybutane-1,2-diol. Its reaction with alkaline sodium arsenite, "Na₃AsO₃," gave the arsonic acid in ~50% yield, as two pairs of diastereoisomers, each pair being a racemic mixture.

Keywords 2,3,4-Trihydroxybutylarsonic acids; 3,4-epoxy-1-butene; 3,4-epoxybutane-1,2-diol; 3,4-butene-1,2-diol; 1,3-butadiene diepoxide; chloramine T; trichloroisocyanuric acid

INTRODUCTION

More than 100 arsenic-containing lipids or their precursors have been found in nature in very small amounts.¹ Their role is not very well understood, but it seems that they are formed in an attempt to detoxify an organism from the arsenic because arsenic in most of these end compounds is in the form of either RR'_3As^+ or $RR'_2As=O$, which is somewhat chemically inert. A phosphonate analogue of phosphatidylcholine has been prepared having $-AsMe_3^+$ instead of $-NMe_3^+$.²

This laboratory has long been involved in the synthesis of arsenic-containing lipids having a functional As(V) in the sense that it can react under very mild conditions with biologically important thiols, e.g., glutathione. Such lipids are the arsonolipids **1** (*rac*-,³ *R*-^{4,5} and *S*-^{4,5}), **2** (*rac*-⁶), and **3**,⁷ as well as the arsinolipids **4** as analogs of bisphosphatidic acid⁸ and of cardiolipin.⁹

From these lipids, the arsonolipids **1** have been studied further, and they have been found to exhibit interesting biophysical properties, e.g.,

Received 15 January 2007; accepted 11 June 2007.

Address correspondence to Panayiotis V. Ioannou, Department of Chemistry, University of Patras, Patras, Greece. E-mail : ioannou@chemistry.upatras.gr

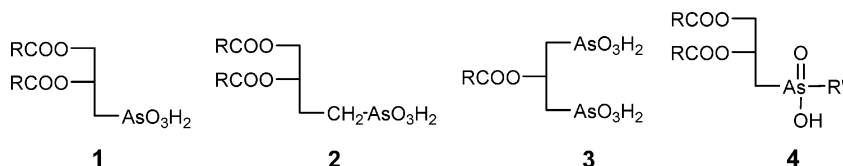

they transport divalent cations through a chloroform phase¹⁰ and form liposomes.¹¹ They can inhibit enzymes, e.g., carbonic anhydrase,¹² and are (poor) substrates for phospholipase A₂.¹³ From the biological point of view they are selectively toxic towards certain cancer cells,^{14,15} while they show promising antileishmanial and trypanocidal activities.¹⁶ Most of these studies have been summarized in recent reviews.^{1,17} Incorporating arsenic into arsonolipids is hoped to reduce the toxicity and the poor absorption seen in As₂O₃—a drug used to treat relapsing acute promyelotic leukemia¹⁸ or multiple myeloma.¹⁹

The properties of arsonolipids **1** made us wonder what could be the properties of arsonolipids **5** having three instead of two fatty acyl chains. Although the ester **6** was prepared *en route* to *D*-erythritol 4-phosphate **7**,²⁰ no long-chain phospho- or phosphonolipids have been prepared.

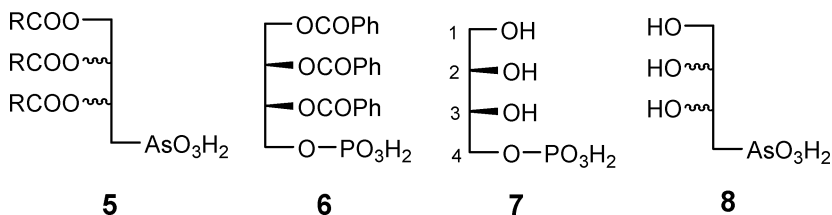

Since esters of arsenic(V) acids are hydrolytically extremely unstable,²¹ a major challenge in the synthesis of optically active **8** is to obtain a chiral compound suitable for the creation of a hydrolytically stable C-As bond. Such compounds should be 2-haloalcohols or epoxides,²² and can be prepared from *meso*-erythritol, tartaric acids, and ascorbic acids in multistep preparations requiring regiospecific protection of the -OH group(s) and timely deprotections.

Before embarking in such preparations, we wanted to explore the chemistry of a bit more complex 2-haloalcohols and of epoxides in their reaction with alkaline arsenite (the Meyer reaction^{23,24}). In this paper, we describe our results on the preparation of the suitable substrates **10** and **12** starting from the commercially available compounds **9** and **11**, as well as on the reaction of **13** with alkaline arsenite, as shown in Scheme 1. Our aim was to find out which compounds can give the arsonic acid **8** with maximum yield and fewer and easily separable by-products.

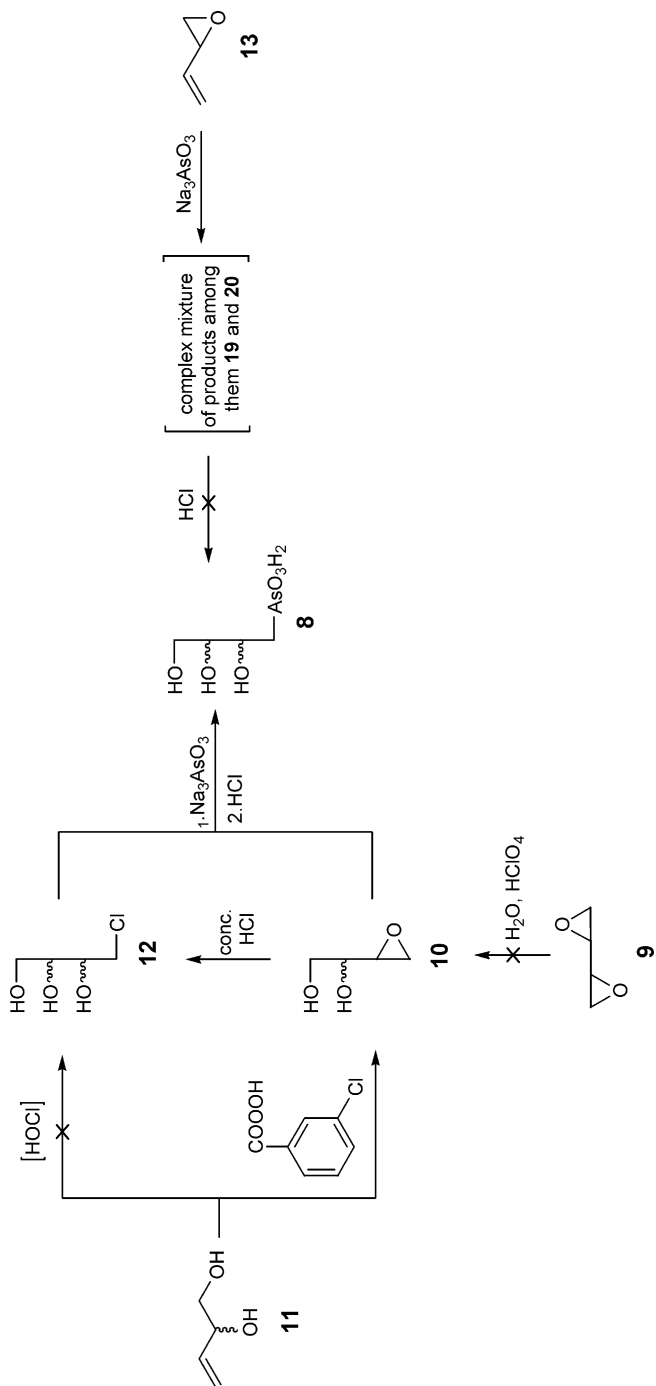

SCHEME 1

RESULTS AND DISCUSSION

Attempted Preparation of the Substrates **10** and **12** from **9** and **11**

The epoxide ring of glycidol (2 M solution in dry THF containing an equimolar amount of water and 1 mol % perchloric acid) was completely opened to give glycerol after 72 h stirring at RT or in less than 30 min at reflux. Under the same conditions, however, equimolar quantities of *DL*-butadiene diepoxide **9** and water gave traces of **10**, and equal quantities of **9** and tetritol (by TLC; AcOEt/peth 1:1) at RT. At reflux after 2 h nearly equal quantities of **9** and tetritol were detected, while after 3 h a white translucent solid appeared which probably was polymerized diepoxide and was not studied further.

The inability of selectively opening one epoxide ring of **9** to give **10** means that **10** reacts, at least, as fast as being formed with water to give the tetritol. The reason for this fast ring opening is not clear. A probable explanation is that of local high concentration of water molecules around the hydrophilic **10** due to hydrogen bonding.

Since alkyl halides²⁵ and the more hydrophilic 2-haloalcohols^{22,26,27} are substrates for the Meyer reaction with aqueous alkaline arsenite, we sought the preparation of **12** from **11** by in situ generating hypochlorous acid according to literature procedures. Chloramine T in the presence of sulfuric acid in acetone-water gives HOCl, which adds to alkenes having hydrogen or alkyl substituents to give chlorohydrins.²⁸ Similarly, trichloroisocyanuric acid in acetone-water hydrolyses to HOCl which adds to unfunctionalized alkenes to give chlorohydrins.²⁹

With **11** as substrate these two reagents did not afford any **12** (TLC analysis), probably because other reactions took place. Inspection of **11** shows that it is both an allyl alcohol and a diol. Although hypochlorination of allyl alcohol by hypochlorous acid does take place (giving the Markovnikov (73%) and anti-Markovnikov (27%) product)³⁰ it was found that chloramine T at all pH values oxidizes allyl alcohol to acrolein ($\text{CH}_2=\text{CH}-\text{CHO}$).^{21,32} Therefore, compound **12** was prepared from **10** as described below.

Preparation of the Substrates **10** and **12**

*Preparation of the Epoxide **10***

During the epoxidation of **11** to **10**³³ by *m*-chloroperbenzoic acid in dichloromethane, tetritol was produced by acid catalyzed ring opening of **10** due to water in the peracid but was not detected by TLC because it co-precipitated with the insoluble *m*-chlorobenzoic acid. The products were extracted with minimum amounts of water, the phases being efficiently separated only by centrifugation, and the solvent water was

removed by freeze drying. The oil obtained in ~90–95% crude yield contained, by ^1H NMR, 60–70% **10**, 20–30% tetritol, <5% **11** and <5% *m*-chlorobenzoic acid, and it was stable at -20°C for >3 months.

The epoxidation of racemic **11** will produce two pairs of diastereomers, each pair being a racemic mixture. In the ^1H NMR spectrum, we observed the epoxide CH_2 protons of the pairs of diastereoisomers of **10** at different shifts from which a ratio of 1:1.62 was calculated. The ^{13}C NMR spectrum showed two peaks of unequal intensity for each of the epoxide carbon atoms and for the CHOH group, while for the CH_2OH moiety a singlet was observed due to pairs **14/15** (threo) and **16/17** (erythro). The pair which predominates should be the **14/15** one.³⁴

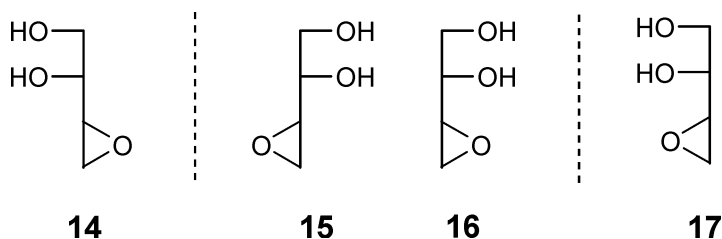

Preparation of the Chloride **12** from **10**

The ring opening of styrene epoxide and butadiene monoxide by HCl gives the chlorides with the $-\text{Cl}$ attached to the secondary carbon atom,^{35,36} while with epichlorohydrin and with glycidol the Cl^- anion attacks the primary carbon atom.³⁷ The addition of crude **10** to concentrated hydrochloric acid gave the chloride **12** as two pairs of diastereomers. As was revealed by ^{13}C NMR spectroscopy, $\text{CH}_2(\text{OH})\text{CH}(\text{OH})\text{CHClCH}_2\text{OH}$ was not formed under the above conditions. The purification of **12** from the tetritol present in crude **12** was done by precipitation, which can be conveniently followed by TLC. However, the product **12** was contaminated by <10% *trans*-3,4-dihydroxytetrahydrofuran^{38,39} as shown by the ^1H and especially by the ^{13}C NMR spectra. Its formation probably took place during the reaction by attack of the terminal $-\text{OH}$ on the protonated **10** or its primary carbocation $\text{CH}_2(\text{OH})\text{CH}(\text{OH})\text{CH}(\text{OH})\text{CH}_2^+$. When the crude chloride **12** was distilled the distillate contained mostly 3,4-dihydroxytetrahydrofuran. In this case the cyclization took place by nucleophilic attack of the terminal $-\text{OH}$ group on the $-\text{CH}_2\text{Cl}$ moiety.

Summarizing, the preparation of **10** from **11** as a pair of diastereoisomers gives impure product. The impurities do not affect the Meyer reaction for the preparation of **8**. Therefore **10** seems to be a good substrate, and moreover, it can be obtained in optically active forms.³⁴ Also the chloride **12** was not obtained pure, and although

the contaminants do not interfere with the Meyer reaction, its very high viscosity will require dilution, which is not desirable.²² Another drawback is, that the Meyer reaction with 2-haloalcohols takes place both via the direct displacement of $-\text{Cl}$ by AsO_3^{3-} and via the attack of AsO_3^{3-} on the epoxide which is formed in the alkaline medium,^{22,26} thus lowering somewhat the yields.

Reaction of **13** with Aqueous Alkaline Arsenite

Butadiene monoxide, **13**, is the simplest vinyl oxirane and in nucleophilic reactions can give four different products depending on the softness/hardness of the nucleophile.^{40,41} Hard nucleophiles attack at the epoxide carbon atoms giving 1,2 or 2,1 addition products, while soft nucleophiles attack at the ethylenic CH_2 carbon atom giving 1,4-conjugate addition products or 3,4-addition products.

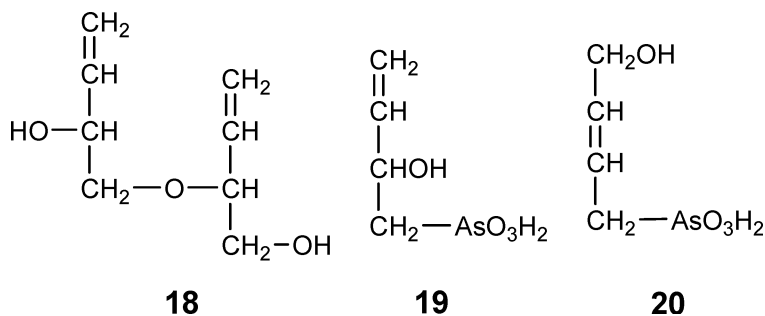

Aqueous alkaline arsenite " Na_3AsO_3 " contains the non-nucleophilic H_3AsO_3 and H_2AsO_3^- , the slightly nucleophilic HAsO_3^{2-} , and the nucleophilic AsO_3^{3-} as well as HO^- .^{22,26} The role of the HO^- was studied with the reaction of **13** with aqueous NaOH , which gave >90% of **11**. Column chromatography gave a fraction containing **11** and the dimer **18**. The structure of **18** was deduced by ^1H NMR: $\delta = 4.35$ (m, 1H for $\text{CH}_2=\text{CH}-\text{CH}(\text{OH})-\text{CH}_2-$), 3.97 (m, 1H for $\text{CH}_2=\text{CH}-\text{CH}(\text{O}-)\text{CH}_2\text{OH}$) and 5.76 (m, 2H for two $\text{CH}_2=\text{CH}$ groups); the other peaks overlap with those of **11**. The dimer was formed by attack of the anion $\text{CH}_2=\text{CHCH}(\text{O}^-)\text{CH}_2\text{OH}$ on another molecule of **13** before being protonated by water. The formation of **11** was expected since HO^- is a hard base, and it is in line with the product (3-hydroxy-4-methoxy-1-butene) obtained from the reaction of **13** with methanolic MeO^- .⁴²

The reaction of equimolar quantities of **13** and " Na_3AsO_3 " at RT/24 h gave " AsO_3^{3-} " (by TLC). The ^1H NMR spectrum of the crude product was very complicated. From it, traces of **11** and **18** were detected and peaks due to $-\text{CH}_2\text{AsO}_3^{2-}$, $\text{CH}_2=\text{CH}-$, and *cis* and *trans* $-\text{CH}=\text{CH}-$ were observed. Therefore, compounds like the salts of **19** and **20** might

have been formed by the attack of the not so hard AsO_3^{3-} on C-1 and C-4 of **13**. Acidification to pH 7 showed the presence of $-\text{CH}_2\text{AsO}_3^{2-}$ ($\delta^1\text{H} = 2.10$ ppm) and $-\text{CH}_2\text{AsO}_3\text{H}^-$ ($\delta^1\text{H} = 2.75$ ppm), but no pure product could be isolated at this stage. Acidification to pH 2 was expected to give the free acids **19** and **20**. However, the ^1H NMR spectrum did not show the signal of $-\text{CH}_2\text{AsO}_3\text{H}_2$ at the expected²⁷ 2.85 ppm. Evidently, **19** or **20**, or both decomposed. H_3AsO_4 was not produced (by magnesia mixture test), therefore the decomposition produced H_3AsO_3 . A probable organic decomposition product, 2,5-dihydrofuran (b.p. 66°C), could not be identified by ^1H NMR. Unstable arsonic acids are known in the chemistry of arsenic,⁴³ and **19/20** may be two of them. Therefore, butadiene monoxide **13**, which can be obtained in optically active forms,^{44,45} cannot be used for the preparation of the target arsonic acid **8**.

Preparation of **8** from **10** and from **12**

The addition of **10** to the concentrated²² solution of alkaline arsenite was not a problem because it was not very viscous; however, the reaction mixture became very viscous and it was difficult to stir. After neutralization with hydrochloric acid, the sodium chloride could not be removed by extracting the crude **8** with boiling methanol, as was done with 2,3-dihydroxypropylarsonic acid, DPAH_2 .²⁷ Removal of sodium chloride was effected by passing the aqueous solution through a strong cation exchange resin.⁴⁶ From the eluate, the hydrochloric acid must be completely removed because the chloride deteriorates the strong anion exchange resin in acetate form to be used in the next step for purification of **8**. From this anion resin, elution with water removed As_2O_3 ⁴⁷ and non arsenic containing impurities, such as tetritol. Elution with aqueous 1 M acetic acid gave the product **8** as a glass which was slowly and with difficulty converted into a powder by trituration. The powder kept tenaciously small amounts of acetic acid, of methanol and, probably, of water. The yields were $\sim 50\%$, which is less than the 70% yields of DPAH_2 obtained from the reaction of glycidol with alkaline arsenite.⁴

Due to its high viscosity, **12** has to be added as a solution to concentrated aqueous alkaline arsenite. Protic solvents, like water or methanol, will dilute the concentrated alkaline arsenite thus diminishing the concentration of the nucleophilic AsO_3^{3-} .²⁶ We have chosen to add **12** as a light suspension in ether into the concentrated alkaline arsenite at 40°C . Then, the ether evaporates and **12** enters the aqueous phase. After work up the product **8** was isolated in $\sim 30\%$ yield compared to 45% yield obtained for the preparation of DPAH_2 using 1-chloro-2,3-propanediol.²⁷ Comparing the yields of **8** prepared from **10** and from **12** it is clear that in the synthesis from **12** the yield is inferior. This is due to the fact that the reaction of 2-haloalcohols with AsO_3^{3-}

proceeds both via direct attack of AsO_3^{3-} on $-\text{CH}_2\text{Cl}$ and on the epoxide, which is formed under the strongly alkaline conditions used.²⁶ This in situ cyclization consumes HO^- , which is necessary to maximize the concentration of the nucleophilic AsO_3^{3-} .²⁷

Starting from racemic **11** two pairs of diastereoisomeric **8** should be obtained, each pair consisting of a racemic mixture. The prepared **8** decomposed at $\sim 218^\circ\text{C}$, while the racemic DPAH_2 decomposed at 202°C .²⁷ The IR and NMR spectra of **8** prepared from **10** and from **12** were identical. The ^{13}C NMR spectra showed that the two pairs of diastereoisomers have been produced in unequal amounts ($\sim 2:1$), but which pair predominates is not known with certainty. Most likely it is the pair arising from the **14/15** pair because it was found to predominate during the epoxidation of racemic **11**.

The IR and NMR spectra of the barium salts of **8** produced from **10** and from **12** were the same. The $-\text{AsO}_3^{2-}$ band in their solid state IR spectra was at 824 cm^{-1} as expected. In the ^1H NMR spectra the $\text{CH}_2\text{AsO}_3^{2-}$ hydrogen atoms showed a strong signal at 2.26 ppm. The ^{13}C NMR spectra showed two signals for each carbon atom due to the presence of diastereoisomers with a ratio of $\sim 3:1$.

Summarizing, from the substrates tested for the preparation of non-optically active **8** the most promising, from the point of view of steps and yields, is the epoxide **10**. Since this compound can be obtained in optically active forms,³⁴ it can be used for the preparation of optically active **8**, especially after the result obtained, that any Payne rearrangement⁴⁸ will not spoil the stereochemistry.⁴⁹

EXPERIMENTAL

3,4-Epoxy-1-butene (butadiene monoxide), 1,3-butadiene diepoxide (*DL*,^{50,51} m.p. $+4^\circ\text{C}$), 3,4-dihydroxy-1-butene (3-butene-1,2-diol), *m*-chloroperbenzoic acid 77%, and trichloroisocyanuric acid were purchased from Aldrich. Chloramine T (Merck) was recrystallized from water.⁵² Racemic glycidol was prepared from 1-chloro-2,3-propanediol (Aldrich) and methanolic sodium hydroxide according to the literature.⁵³ It was pure by TLC ($\text{CHCl}_3/\text{Me}_2\text{CO}$ 3:1, R_f 0.61). The cation exchange resin Dowex AG 50W-X8 (H^+) and the anion exchange resin Dowex AG 1-X8 (acetate) were obtained from Bio-Rad, while silica gel 60 for column chromatography and silica gel 60 H for thin layer chromatography (TLC) were obtained from Merck. Tetrahydrofuran (THF) was dried by slow percolation through activated alumina.

TLC was run on microslides. Spots were made visible by iodine vapors (especially for " AsO_3^{3-} ") and by spraying with 35% sulfuric acid and charring. A Labconco Freezone 4.5 instrument was used for freeze-drying, while a Kugelrohr B-585 apparatus from Büchi was used for

trap-to-trap distillation. IR spectra were obtained on a Perkin-Elmer 16PC FT-IR spectrometer. ^1H NMR (at 400 MHz) and ^{13}C NMR (at 100 MHz) spectra were obtained with a Bruker DPX Avance spectrometer. TMS was used as standard in CDCl_3 , while DSS [3-(trimethylsilyl)-1-propanesulfonic acid sodium salt] was used as standard in D_2O . Elemental analyses were done by the Centre of Instrumental Analyses, University of Patras, Greece.

Attempted Preparations of **10** from **9** and of **12** from **11**

To a solution of diepoxide **9** ($77\ \mu\text{L}$, 86 mg, 1 mmol) in dry THF (0.5 mL), an aqueous solution containing water (1 mmol) and perchloric acid (0.01 mmol) was added and stirred at RT for 72 h. TLC (AcOEt/peth 1:1) showed the presence of the diepoxide (R_f 0.58), traces of **10** (R_f 0.20), and significant amount of tetritol (R_f 0.0). When a similar solution was refluxed for 8 h nearly equal amounts of diepoxide and tetritol were detected by TLC.

To a solution of chloramine T trihydrate (282 mg, 1 mmol) in acetone (0.5 mL), 3,4-dihydroxy-1-butene **11** ($84\ \mu\text{L}$, 88 mg, 1 mmol) was added followed by dropwise addition of a solution of 95.5% w/w sulfuric acid ($54\ \mu\text{L}$, 98 mg, 1 mmol) in water (0.5 mL), and the solution was stirred at RT for 3 h. After 40 min, hypochlorous acid was not detected (1 drop of the solution added to 1 drop of aqueous sodium iodide and 1 drop of starch solution). TLC ($\text{CHCl}_3/\text{MeOH}$ 2:1) did not show the presence of **12** at R_f 0.72.

To a solution of trichloroisocyanuric acid (78 mg, 0.33 mmol) in acetone (0.5 mL), water (0.1 mL) and **11** ($84\ \mu\text{L}$, 88 mg, 1 mmol) was added and the opalescent solution was stirred at RT for 2 h. The expected product **12** was not detected by TLC.

Preparation of Substrates **10** and **12**

Preparation of 3,4-Epoxybutane-1,2-diol (10)

To a solution of 3-butene-1,2-diol **11** (4.400 g, 50 mmol) in dichloromethane (10 mL) was added dropwise a solution of *m*-chloroperbenzoic acid (12.33 g, purity 77%) in dichloromethane (60 mL), and the mixture was stirred at RT for 4.5 h. During the reaction *m*-chlorobenzoic acid precipitated. TLC ($\text{CHCl}_3/\text{MeOH}$ 10:1) showed peracid + acid (R_f 0.77), **11** (R_f 0.43), and **10** (R_f 0.38). Tetritol (R_f 0.05) was not detected. Filtration (sintered glass porosity 3) removed the precipitated *m*-chlorobenzoic acid plus any co-precipitated tetritol. Concentration to ~ 20 mL gave a suspension which was transferred to a large centrifuge tube and extracted with water (5×5 mL), the phases being separated by centrifugation. In the aqueous phase, the water soluble tetritol was detected by TLC. The combined aqueous phases were

filtered (Pasteur pipette plugged with cotton) to remove precipitated *m*-chlorobenzoic acid, and the clear filtrate was freeze-dried for 12–16 h to give an oil (4.870 g), which by ^1H NMR contained the product **10** (70%), tetritol (26%), starting compound **11** (2%), and *m*-chlorobenzoic acid (1%). The calculated yield of pure **10** was 66%. ^1H NMR (D_2O , DSS): $\delta = 2.83$ [dd, 1.24 H, H_A of the one diastereoisomer ($\text{CH}_\text{A}\text{H}_\text{B}$, epoxide ring)]; 2.86 [dd, 0.76 H, H_A' of the other diastereoisomer ($\text{CH}_\text{A}'\text{H}_\text{B}'$, epoxide ring)]; 2.93 [m, 2H, H_B and H_B' of the two diastereoisomers ($\text{CH}_\text{A}\text{H}_\text{B}$ and $\text{CH}_\text{A}'\text{H}_\text{B}'$, epoxide rings)]; 3.17 (m, 2H, CH of the epoxide ring of the two diastereoisomers); 3.53–3.79 (m, 6H, $\text{CH}_2(\text{OH})\text{-CH}(\text{OH})$ for the two diastereoisomers and the protons from tetritol). ^{13}C NMR (D_2O , DSS) (ratio of intensities in parenthesis): $\delta = 44.9$ and 45.2 (1.8:1) for CH_2 of the epoxide ring, 52.4 and 53.7 (1:1.8) for CH of the epoxide ring, 62.8 for CH_2OH , 70.6 and 71.9 (1:1.9) for CH-OH.

A sample of crude **10** (64 % purity) was stable at -20°C for at least 3 months, while in D_2O it decomposed slowly (27% left after 40 days and 11% left after 90 days at RT).

Preparation of 4-Chlorobutane-1,2,3-triol (**12**)

To concentrated (12 M) hydrochloric acid (2 mL) was added dropwise while stirring 3,4-epoxybutane-1,2-diol **10** (905 mg of 70% purity), and the yellow solution was stirred at RT for 1 h. TLC ($\text{CHCl}_3/\text{MeOH}$ 2:1) showed the presence of **12** (R_f 0.73) and tetritol (R_f 0.42). Evaporation (rotary, 50°C) gave yellow, very viscous oil which was dissolved with slight warming in a minimum amount of methanol (~ 2 mL). Addition of diethyl ether until opalescence and cooling at $+4^\circ\text{C}$ overnight precipitated a brown oil. The supernatant, still containing tetritol, was decanted, more diethyl ether was added till opalescence (total: 40 mL diethyl ether), and cooled at $+4^\circ\text{C}$ overnight. Brown oil was precipitated, and the supernatant was free of tetritol (TLC analysis). It was evaporated and dried in vacuo to give a colorless, very viscous oil (871 mg, expected 857 mg) which according to ^1H NMR contained methanol ($\sim 2\%$), 3,4-dihydroxytetrahydrofuran ($\sim 10\%$) and **12** ($\sim 85\%$). IR (neat): 3350 vs, broad, 2942 m, 1430 m, 1306 mw, 1074 s, 1038 s, 884 mw, 748 m, 680 m. ^1H NMR (D_2O , DSS): $\delta = 3.34$ (s, MeOH impurity), 3.60–3.90 (m, 6H, all methylene and methine protons of **12**). Non-resolved signals of 3,4-dihydroxytetrahydrofuran in the regions of 3.93–4.04 and 4.23–4.27 ppm. ^{13}C NMR (D_2O , DSS) (ratio of intensities in parentheses): For the two diastereoisomers of **12**: CH_2Cl : $\delta = 48.5$ and 49.7 (1.5:1); CH_2OH : $\delta = 65.21$ and 65.25 (1.3:1); $\text{CH}(\text{OH})\text{CH}_2\text{Cl}$: $\delta = 73.5$ and 73.9 (1:1.4); $\text{CH}(\text{OH})\text{CH}_2\text{OH}$: $\delta = 74.4$ and 74.5 (1:1.2). For 3,4-dihydroxytetrahydrofuran: C-1, C-4: $\delta = 75.5$; C-2, C-3: $\delta = 78.9$ for *trans*; the *cis* could not be identified. Que Jr. and Gray³⁸ for *trans*: C-1,

C-4: $\delta = 73.0$; C-2, C-3: $\delta = 76.4$ and for *cis*: C-1, C-4: $\delta = 71.5$; C-2, C-3: $\delta = 73.5$, both in D_2O .

When the crude **12** was distilled (Kugelrohr, $\sim 125^\circ C/0.2$ mm Hg) the oil obtained was a mixture of *cis* and *trans* 3,4-dihydroxytetrahydrofuran (major) and **12** (minor) as revealed by ^{13}C and 1H NMR.^{38,39}

Reaction of **13** with Na_3AsO_3

To a cooled (ice-water) solution of arsenic(III) oxide (198 mg, 1 mmol) and sodium hydroxide (240 mg, 6 mmol) in water (0.5 mL) was added through a septum 3,4-epoxy-1-butene **13** (168 μL , 2.4 mmol) and the reaction mixture was stirred at $0^\circ C$ for 30 min and then at RT for 24 h. TLC (MeOH/conc. NH_3 4:1) of the clear viscous solution showed traces of **13** (R_f 0.90), a spot at R_f 0.77, and AsO_3^{3-} (R_f 0.58). Evaporation and drying in vacuo over P_2O_5 for 4 days gave a sticky, glassy solid, the 1H NMR (D_2O , DSS) of which showed the signal of $-CH_2AsO_3^{2-}$ at 2.15 ppm, of $CH_2=CH$ at 5.30 and ~ 5.8 ppm, of *trans* $-CH=CH-$ at 5.95 ppm, of *cis* $-CH=CH-$ at ~ 6.5 ppm, and other signals in the region 1.8–4.6 ppm. When trifluoroacetic acid was added to the 1H NMR sample adjusting the pH to ~ 2 , the signal at 2.15 ppm disappeared but no signal due to $CH_2AsO_3H_2$ was observed at ~ 2.9 ppm. The new spectrum was still too complicated to be analysed. When a sample of the glassy solid was acidified to pH ~ 7 with HCl, evaporated, dried and analysed by 1H NMR (D_2O , DSS) a weak signal at ~ 2.2 ppm due to $-CH_2AsO_3^{2-}$ and a strong signal at ~ 2.8 ppm due to $-CH_2AsO_3H^-$ were detected, meaning that the monosodium salt of the arsonic acid was stable. Acidification to pH 2 did not produce any free arsonic acid.

Preparation of **8** from Crude **10**

To a solution of arsenic(III) oxide (1.832 g, 9.25 mmol As_2O_3) and sodium hydroxide (2.220 g, 55.5 mmol) in water (4 mL) was added dropwise during 2 h the crude epoxide **10** (2.836 g, purity 68%). The very viscous solution was stirred at RT for 24 h. TLC (MeOH/conc. NH_3 4:1) showed the presence of tetritol (R_f 0.77), AsO_3^{3-} (R_f 0.57), and the salt of **8** (R_f 0.30). To the cooled (cold water) solution was added dropwise 12 M hydrochloric acid (4.6 mL, 55.5 mmol) until a pH of 2 was reached in order to neutralize the basic components of the mixture. Then, the solution was diluted with water (80 mL), applied onto the strongly acidic cation exchange resin Dowex AG 50W-X8 (H^+ form) (2.2×26 cm), and eluted with water (1 L) collecting 250 mL fractions. The fourth fraction gave a white solid (17 mg), which was *m*-chlorobenzoic acid (by IR). The

first three fractions were pooled, evaporated (rotary, 60°C), and dried in vacuo to give a glass (4.976 g). The glass dissolved in water (30 mL), was applied portion-wise (5 × 6 mL) onto a column of the strong anion exchange resin Dowex AG 1-X8 (acetate form) (3 × 32 cm) and eluted with a) water (300 mL) and b) 1 M aqueous acetic acid (1 L) collecting 50 mL fractions. The water eluted As₂O₃ and tetritol (2.006 g), the fractions 8-10 gave an unidentified compound (6 mg) running just above the product **8** on TLC, the fractions 11-13 gave the product **8** (1.963 g) as a glass, and the fractions 14-22 gave a solid (521 mg). Yields of **8**: 46% from **10** and 17% from **11**. The glassy product **8** was insoluble in Et₂O, CHCl₃, Me₂CO, and MeOH. Trituration with warm methanol (~5 mL) transformed the glass into a white solid. M.p.: at ~212°C shrinks and at 218°C decomposes. IR (KBr): 3376 vs, broad, 1638 m, 1400 mw, 1235 mw, 1070 s, 904 s, 768 s, 671 w. ¹H NMR (D₂O, DSS): δ = 2.82 and 2.91 (2 m, 4H, for the CH₂AsO₃H₂ of the two diastereoisomers); 3.58-3.79 (m, 6H, for CH₂OH and CH(OH)CH₂OH of the two diastereoisomers); 4.15 and 4.22 (2 m, 2H, for CH(OH)CH₂As of the two diastereoisomers). ¹³C NMR (D₂O, DSS), (ratio of intensities in parenthesis): δ = 41.0 and 41.2 (1:2.2) for CH₂AsO₃H₂, 64.9 and 65.1 (1:2.2) for CH₂OH, 68.4 and 68.8 (3.1:1) for CH(OH)CH₂AsO₃H₂, 76.5 and 77.3 (2.7:1) for CH(OH)CH₂OH.

For elemental analyses, to 100 mg (~ 0.43 mmol) of impure **8** (containing MeOH and AcOH) dissolved in water (0.5 mL) was added while stirring a clear solution of recrystallized barium hydroxide octahydrate (151 mg, 0.48 mmol) dissolved in methanol (10 mL). The precipitated salt was centrifuged after 2 h, washed with boiling methanol (3 mL), left at RT to cool, centrifuged and dried in vacuo over phosphorus pentoxide. The barium salt of **8** (138 mg, 87%) is a white non-hygroscopic solid, which is moderately soluble in water. Calculated for C₄H₉O₆AsBa (365.37): C 13.15, H 2.48%; found: C 13.43 H 2.28%. IR (KBr): 3326 broad, vs, 1650 m, 1450 m, 1076 s, 1040 ms, 824 vs. ¹H NMR (D₂O, DSS): δ = 2.15-2.34 (m, 2H, for the CH₂AsO₃²⁻); 3.55-3.85 (m, 3H, for the CH₂(OH)CH(OH)-); 4.05-4.20 (m, 1H, for the CH(OH)CH₂As). ¹³C NMR (D₂O, DSS), (ratio of intensities in parenthesis): δ = 39.7 and 40.1 (1:3) for CH₂As; 65.0 and 65.4 (1:3) for CH₂OH; 69.6 and 70.2 (3:1) for CH(OH)CH₂As; 76.9 and 77.5 (3:1) for CH(OH)CH₂OH.

Preparation of **8** from **12**

To a warm (water bath, 40°C) solution of arsenic(III) oxide (540 mg, 2.73 mmol As₂O₃) and sodium hydroxide (654 mg, 16.35 mmol) in water (1.2 mL) was added dropwise during 1.5 h a light suspension of impure **12** (766 mg, 90% purity) in diethyl ether (1 mL) in a way allowing the diethyl ether to evaporate and **12** to enter the aqueous phase. Stirring was

continued for 1 h at 40°C and for further 24 h at RT. TLC (MeOH/conc. NH₃ 4:1) revealed the presence of a large amount of tetritol (R_f 0.62), AsO₃³⁻ (R_f 0.43), and the salt of **8** (R_f 0.23). The cooled (cold water) solution was acidified with 12 M hydrochloric acid (0.9 mL, 10.9 mmol) to pH 2 and subjected to chromatography, as described above, using the strong acidic and the strong basic resins. The product **8** was a glass (441 mg), which on trituration with warm methanol (2 mL) gave a white solid. Yields of **8**: 31% from **12**, 11% from **11**. The IR, ¹H and ¹³C NMR spectra were the same as those obtained for the product prepared from **10**.

For elemental analyses, the impure **8** (containing MeOH and AcOH) was converted into its barium salt, as previously described. Yield 81%. Calculated for C₄H₉O₆AsBa (365.37): C 13.15, H 2.48%; found C 13.13, H 2.48%. The IR, ¹H and ¹³C NMR spectra of the barium salt of **8** produced from **12** were identical to those obtained for the product from **10**.

REFERENCES

- [1] V. M. Dembitsky and D. O. Levitsky, *Prog. Lipid Res.*, **43**, 403 (2004).
- [2] T. Junk, G. C. Pappalardo, and K. J. Irgolic, *Appl. Organomet. Chem.*, **4**, 103 (1990).
- [3] G. M. Tsivgoulis, D. N. Sotiropoulos, and P. V. Ioannou, *Phosphorus, Sulfur, and Silicon*, **63**, 329 (1991).
- [4] S. V. Serves, G. M. Tsivgoulis, D. N. Sotiropoulos, and P. V. Ioannou, *Phosphorus, Sulfur, and Silicon*, **71**, 99 (1992).
- [5] S. V. Serves, D. N. Sotiropoulos, P. V. Ioannou, and M. K. Jain, *Phosphorus, Sulfur, and Silicon*, **81**, 181 (1993).
- [6] S. V. Serves, D. N. Sotiropoulos, and P. V. Ioannou, *Phosphorus, Sulfur, and Silicon*, **106**, 75 (1995).
- [7] A. Terzis and P. V. Ioannou, *Chem. Phys. Lipids*, **117**, 53 (2002).
- [8] N. L. Kordalis and P. V. Ioannou, *Appl. Organomet. Chem.*, **14**, 273 (2000).
- [9] P. V. Ioannou, *Chem. Phys. Lipids*, **117**, 7 (2002).
- [10] O. Gortzi, P. Klepetsanis, S. G. Antimisiaris, and P. V. Ioannou, *Chem. Phys. Lipids*, **112**, 21 (2001).
- [11] D. G. Fatouros, O. Gortzi, P. Klepetsanis, S. G. Antimisiaris, M. C. A. Stuart, A. Brisson, and P. V. Ioannou, *Chem. Phys. Lipids*, **109**, 75 (2001).
- [12] C. T. Supuran, S. V. Serves, and P. V. Ioannou, *J. Inorg. Biochem.*, **62**, 207 (1996).
- [13] J. Rogers, B.-Z. Yu, S. V. Serves, G. M. Tsivgoulis, D. N. Sotiropoulos, P. V. Ioannou, and M. K. Jain, *Biochemistry*, **35**, 9375 (1996).
- [14] O. Gortzi, E. Papadimitriou, C. G. Kontoyannis, S. G. Antimisiaris, and P. V. Ioannou, *Pharm. Res.*, **19**, 79 (2002).
- [15] O. Gortzi, S. G. Antimisiaris, P. Klepetsanis, E. Papadimitriou, and P. V. Ioannou, *Eur. J. Pharm. Sci.*, **18**, 175 (2003).
- [16] S. G. Antimisiaris, P. V. Ioannou, and P. M. Loiseau, *J. Pharm. Pharmacol.*, **55**, 647 (2003).
- [17] D. G. Fatouros, P. V. Ioannou, and S. G. Antimisiaris, *J. Nanosc. Nanotech.*, **6**, 2618 (2006).

- [18] S. L. Soignet, S. R. Frankel, D. Douer, M. S. Tallman, H. Hantarjian, E. Calleja, R. M. Stone, M. Kalaycio, D. A. Scheinberg, P. Steinerherz, E. L. Sievers, S. Coutre, S. Dahlberg, R. Ellison, and R. P. Warrell, *J. Clin. Oncol.*, **19**, 3852 (2001).
- [19] N. C. Munshi, G. Tricot, R. Desikan, A. Bardos, M. Zangari, A. Toor, C. Morris, E. Anaissie, and B. Barlogie, *Leukemia*, **9**, 1835 (2002).
- [20] D. L. MacDonald, H. O. L. Fieser, and C. E. Ballou, *J. Am. Chem. Soc.*, **78**, 3720 (1956).
- [21] J. W. Long and W. J. Ray Jr., *Biochemistry*, **12**, 3932 (1973).
- [22] P. V. Ioannou, *Phosphorus, Sulfur, and Silicon*, **177**, 1 (2002).
- [23] G. Meyer, *Ber. Dtsch. Chem. Ges.*, **16**, 1439 (1883).
- [24] G. V. Chelintsev and V. K. Kushkov, *J. Gen. Chem. USSR*, **16**, 1481 (1946); *Chem. Abstr.*, **41**, 5441a (1947).
- [25] C. K. Banks, J. F. Morgan, R. L. Clark, E. B. Hatlelid, F. H. Kahler, W. H. Paxton, E. J. Cragoe, R. J. Andres, B. Elpern, R. F. Coles, J. Lawhead, and C. S. Hamilton, *J. Am. Chem. Soc.*, **69**, 927 (1947).
- [26] S. V. Serves, D. N. Sotiropoulos, P. V. Ioannou, and H. B. F. Dixon, *Phosphorus, Sulfur, and Silicon*, **90**, 103 (1994).
- [27] G. M. Tsigvoulis, D. N. Sotiropoulos, and P. V. Ioannou, *Phosphorus, Sulfur, and Silicon*, **57**, 189 (1991).
- [28] B. Damin, J. Garapon, and B. Sillion, *Synthesis*, **362**, (1981).
- [29] M. Wengert, A. M. Sanseverino, and M. C. S. de Mattos, *J. Braz. Chem. Soc.*, **13**, 700 (2002).
- [30] L. S. Boguslavskaya, *Russ. Chem. Rev.*, **41**, 740 (1972).
- [31] D. S. Mahadevappa and H. M. K. Naidu, *Talanta*, **20**, 349 (1973).
- [32] D. S. Mahadevappa and H. M. K. Naidu, *Aust. J. Chem.*, **27**, 1203 (1974).
- [33] B. T. Golding, P. K. Slaich, and W. P. Watson, *IARC Scientific Publication*, No 70, 227 (1986).
- [34] D. J. Claffey and J. A. Ruth, *Tetrahedron Lett.*, **37**, 7929 (1996).
- [35] F. A. Long and J. G. Pritchard, *J. Am. Chem. Soc.*, **78**, 2663 (1956).
- [36] J. G. Pritchard and F. A. Long, *J. Am. Chem. Soc.*, **78**, 2667 (1956).
- [37] L. Smith and S. Skyle, *Acta Chem. Scand.*, **4**, 39 (1950).
- [38] L. Que Jr. and G. R. Gray, *Biochemistry*, **13**, 146 (1974).
- [39] J. Skarewski and A. Gupta, *Tetrahedron Asymmetry*, **8**, 1861 (1997).
- [40] A. S. Rao, K. S. Pakniker, and J. G. Kirtane, *Tetrahedron*, **39**, 2323 (1983).
- [41] C. Jaime, R. M. Ortuño, and J. Font, *J. Org. Chem.*, **53**, 139 (1988).
- [42] R. G. Kadesch, *J. Am. Chem. Soc.*, **68**, 41 (1946).
- [43] H. B. F. Dixon, *Adv. Inorg. Chem.*, **44**, 191 (1997).
- [44] C. Neagu and T. Hase, *Tetrahedron Lett.*, **34**, 1629 (1993).
- [45] D. J. Claffey and J. A. Ruth, *Tetrahedron Asymmetry*, **8**, 3715 (1997).
- [46] A. -M. Lacoste, C. Dumora, B. R. S. Ali, E. Neuzil, and H. B. F. Dixon, *J. Gen. Microb.*, **138**, 1283 (1992).
- [47] S. V. Serves, D. N. Sotiropoulos, P. V. Ioannou, E. K. Mutenda, M. J. Sparkes, and H. B. F. Dixon, *Phosphorus, Sulfur, and Silicon*, **101**, 75 (1995).
- [48] G. B. Payne, *J. Org. Chem.*, **27**, 3819 (1962).
- [49] L. Kürti and B. Czakó, *Strategic Applications of Named Reactions in Organic Synthesis* (Elsevier, Amsterdam, 2005), pp. 336-337.
- [50] W. F. Beech, *J. Chem. Soc.*, 2483 (1951).
- [51] P. W. Feit, *Chem. Ber.*, **93**, 116 (1960).
- [52] A. I. Vogel, *Practical Organic Chemistry* (Longmans, London, 1964), 3rd edition, Ch. IV, p. 824.
- [53] T. H. Rider and A. J. Hill, *J. Am. Chem. Soc.*, **52**, 1521 (1930).