



End-to-End Continuous Manufacturing of Pharmaceuticals: Integrated Synthesis, Purification, and Final Dosage Formation**

Salvatore Mascia, Patrick L. Heider, Haitao Zhang, Richard Lakerveld, Brahim Benyahia, Paul I. Barton, Richard D. Braatz, Charles L. Cooney, James M. B. Evans, Timothy F. Jamison, Klavs F. Jensen, Allan S. Myerson, and Bernhardt L. Trout*

For the past decade, the pharmaceutical industry has been under pressure to improve efficiency, as rising costs outpaced the development of new pharmaceuticals.^[1] A growing interest in green processes also highlights areas for possible improvements in pharmaceutical synthesis and manufacturing, where environmental impacts have been higher than for other industries.^[2] Continuous manufacturing has attracted the attention of industry and academia alike by promising lower costs, greater reliability and safety, better sustainability, and novel pathways that are not otherwise accessible.^[3] Recent studies have demonstrated that economic savings can be realized for certain cases by transforming a batch production into a continuous process.^[4] With existing batch-based manufacturing methods, it can take up to 12 months between the start of the first synthetic step and market release of finished tablets,^[5] which partially results from movement of materials around and between facilities, and lengthy final-product testing. This results in large and expensive inventories, and shortages from manufacturing delays if the batch fails during the final testing once the production has finished. Continuous manufacturing allows faster response to changes in demand; this permits a smaller inventory than for batch-based manufacturing, which not only results in lower working capital, but also decreases the stored amounts of potentially hazardous intermediates, including high-potency active pharmaceutical ingredients (API). Increasing the use of online monitoring and control also reduces the burden of final

testing, which mirrors the online control present in other continuous-manufacturing industries.^[6] Simulations of processes that include recycle loops demonstrated that improvements in process yield and robustness can be achieved by operating continuously.^[7] In spite of these promising results, there are still many hurdles to be overcome during the implementation of continuous processes.^[2b,8] These include development of flow chemistry transformations, difficulties with processing dry solids and solid-laden fluids, lack of equipment at bench and pilot scale, development of control methodologies to guarantee product quality, and breaks in the process, especially between synthesis and formulation. Many examples have been reported of continuous processes for chemical synthesis in flow,^[9] reactions with workup,^[10] continuous crystallization,^[10b,11] drying,^[12] powder blending,^[13] and tableting;^[13d,14] however, only few others have considered multistep portions of a process.^[9h,10b,13d,14c,15]

Herein, we present the first example of an end-to-end, integrated continuous manufacturing plant for a pharmaceutical product. Our plant starts from a chemical intermediate and performs all the intermediate reactions, separations, crystallizations, drying, and formulation, which results in a formed final tablet in one tightly controlled process. This provides a platform to test newly developed continuous technologies within the context of a fully integrated production system, and to investigate the system-wide performance of multiple interconnected units. Herein, the key results of operating the plant for runs of up to ten days are presented. The ten-day period included start-up of the plant, stabilization of key processes, and periods of end-to-end operation. We specifically highlight areas where we took advantage of continuous-flow features, and discuss techniques relevant to continuous processes.

The target API is aliskiren hemifumarate (**6**; Scheme 1), which is formulated as tablets containing 112 mg of the free base form of aliskiren (**5**). The total throughput of the plant is nominally 45 g h⁻¹ of **6**, which corresponds to 2.7 × 10⁶ tablets y⁻¹. The throughput can be adjusted to values between 20 g h⁻¹ and 100 g h⁻¹ by changing control setpoints in the plant. The plant layout is compact, with a 2.4 × 7.3 m² footprint, and the plant is entirely contained within enclosures. The major unit operations in the plant are shown in Figure 1. A more detailed diagram that includes the automated control loops used to ensure product quality is provided in the Supporting Information (Figure S1). The number of unit operations could be reduced from 21 for the batch process to 14 for the continuous process, mainly

[*] S. Mascia, P. L. Heider, H. Zhang, R. Lakerveld, B. Benyahia, P. I. Barton, R. D. Braatz, C. L. Cooney, J. M. B. Evans, K. F. Jensen, A. S. Myerson, B. L. Trout
Department of Chemical Engineering
Massachusetts Institute of Technology (MIT), Cambridge (USA)
E-mail: trout@mit.edu

T. F. Jamison
Department of Chemistry, MIT (USA)

[**] We thank Novartis International AG for funding and supplying our starting chemical intermediates. We would like to acknowledge the contribution of the pilot plant team, including Soubir Basak, Erin Bell, Stephen Born, Louis Buchbinder, Ellen Cappo, Corinne Carland, Alyssa N. D'Antonio, Joshua Dittrich, John Fisher, Megan A. Foley, Ryan Hartman, Devin Hershey, Rachael Hogan, Bowen Huo, Anjani Jha, Ashley S. King, Tushar Kulkarni, Timur Kurzej, Aaron Lamoureux, Paul S. Madenjian, Sean Ogden, Ketan Pimparkar, Joel Putnam, Anna Santiso, Jose C. Sepulveda, Min Su, Daniel Tam, Mengying Tao, Kristen Talbot, Christopher J. Testa, Justin Quon, Forrest Whitcher, and Aaron Wolfe.

Supporting information for this article is available on the WWW under <http://dx.doi.org/10.1002/anie.201305429>.

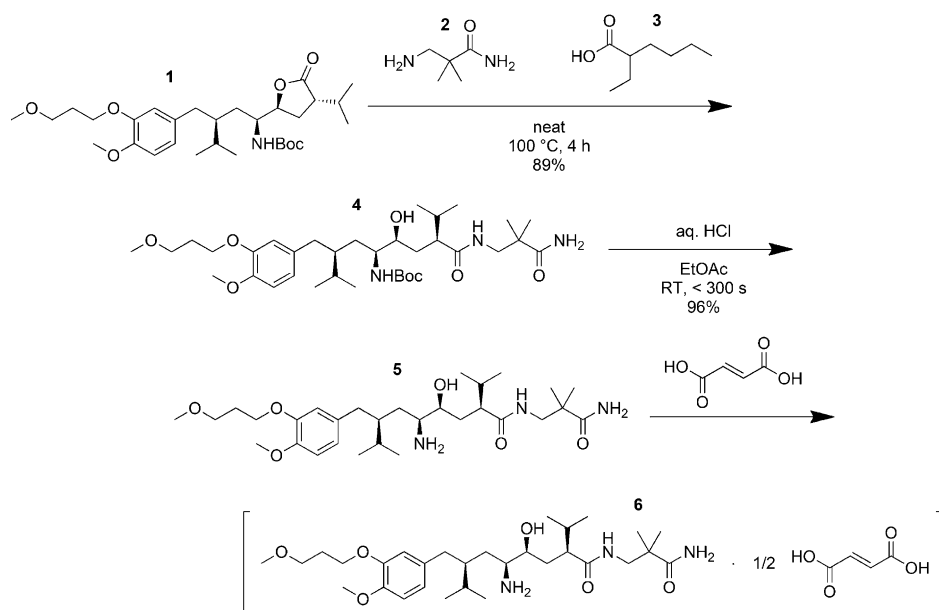

Scheme 1. Synthetic steps from intermediate 1 to aliskiren hemifumarate (6).

times for the batch process (300 h, not including off-line holding and transport).^[16] This was achieved by realizing shorter processing times across all unit operations (Table 1).

A detailed description of the process is provided in the Supporting Information; however, a brief description is provided here to highlight instances where we took advantage of the continuous and integrated features of the plant. The process starts with the chemical intermediate 1 that is melted and pumped into a tubular reactor (R1) at 100 °C, where it is mixed with amine 2 (10 equiv) and acid catalyst 3 (1 equiv), and reacts reversibly to compound 4. This reaction was developed^[17] specifically for

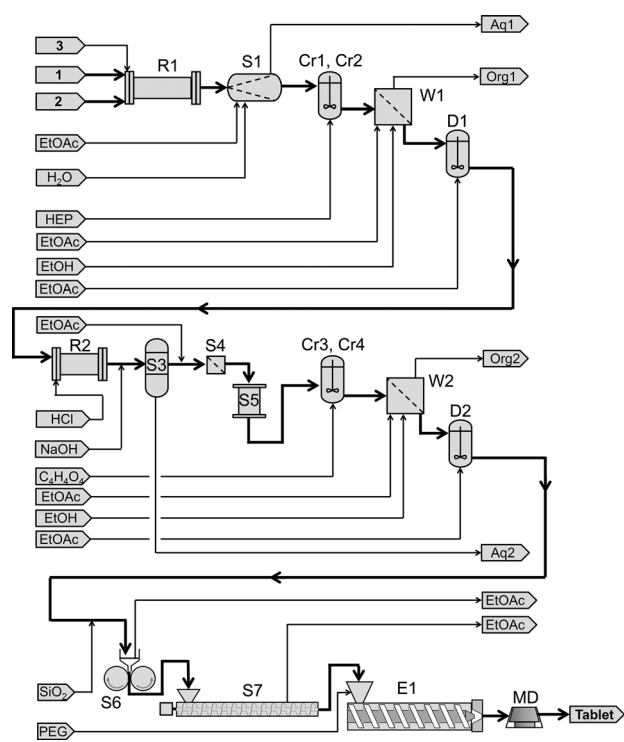

Figure 1. Process flow diagram including the major unit operations. R reactor, S separation, Cr crystallization, W filter/wash, D dilution tank, E extruder, MD mold. A detailed diagram is provided in the Supporting Information (Figure S1).

because of improvements in the downstream steps using continuous-flow technologies. For instance, steps such as mixing, granulation, drying, and compression forming are replaced by a single integrated extrusion and molding device. The process residence time is nominally 47 h, which is nearly an order of magnitude shorter than the sum of the processing

Table 1: Nominal residence times for the continuous process.

Unit operation ^[a]	<i>t</i> [h]
R1	4
S1	< 0.1
Cr1 + Cr2	8
W1	< 0.1
D1	2
R2	< 0.1
S3	2
S5	15
Cr3 + Cr4	8
W2	< 0.1
D2	2
S6 + S7	6
E1	< 0.1
MD	< 0.1
Total	47

[a] Unit operations refer to the designations given in Figure 1.

the flow process and provides several advantages over the batch process. When run neat in a single-phase reaction, the reaction is much faster than existing batch processes, which can also produce solids (3–4 h vs. 72 h).^[18] Workup is performed inline by adding water and ethyl acetate under pressure (7.5×10^5 Pa) at the reaction temperature, to solubilize the reagents before cooling. This is more easily done in flow, where the solvents are mixed at temperatures above their boiling points, whereas in a batch process, cooling of the crude reaction mixture results in a highly viscous liquid that is difficult to mix. The two-phase stream is separated using a membrane-based liquid–liquid separator (S1) that is scaled up from microfluidic flow applications.^[19] The organic phase contains only 1 and 4, whereas the aqueous phase removes 2 and 3.

The separated organic phase is fed into a two-stage, mixed suspension, mixed product removal (MSMPR) crystallization

process (Cr1 and Cr2).^[20] The solution is cooled to 5 °C and mixed with the antisolvent heptane. The slurry is then fed into an in-house-built continuous filter (W1). A thin layer of slurry is formed over a rotating porous plate, and is washed with ethyl acetate and ethanol. Vacuum is applied to the back side of the plate, and pulls the mother liquor and wash solvent through; then, the purified wet cake is scraped off and conveyed into another vessel (D1). A density flow cell in a side loop monitors the concentration of compound **4** in the vessel and feedback control adjusts the flow rate of an ethyl acetate dilution stream to maintain the concentration at 26.2 wt%, which is measured by the density meter, as required for the second reaction of **4** to **5** (shown in Scheme 1).

This movement of material, from the crystallization through the filter into the second reaction, provides an example where a critical material attribute (CMA) of a key intermediate is controlled within the process (Figure 2). A

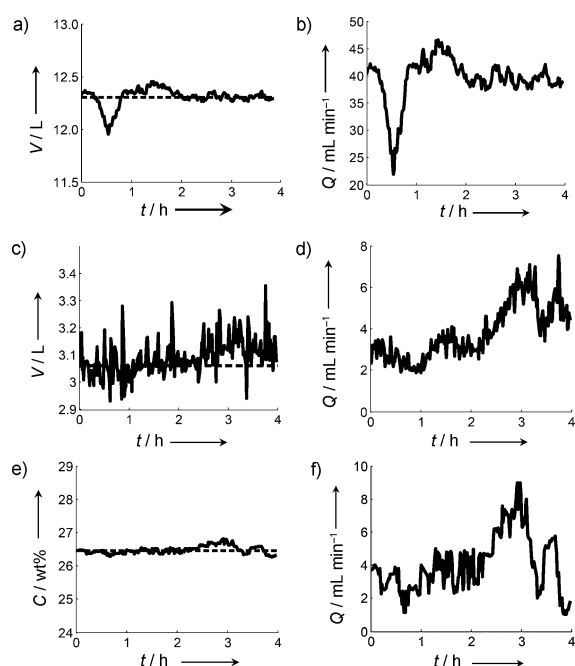

Figure 2. Example of disturbance mitigation through a cascade of three integrated unit operations after several days of operation: a) volume in Cr2, b) outlet flow rate of Cr2, c) volume in D1, d) outlet flow rate of D1, e) concentration of **4** in D1, f) solvent flow rate into D1. The setpoints in a, c, and e are marked as horizontal dashed lines and a constant steady-state offset as a result of proportional-only control has been subtracted.

detailed study of the CMAs and their control has been previously reported.^[21] Control for the process is split into two layers, stabilizing and quality, which operate simultaneously. The stabilizing control layer consists of automated level control loops that maintain sufficient holdup in each vessel, while the quality control layer maintains the desired product quality (by targeting CMAs). The propagation of a disturbance originating from Cr1 after several days of operation is shown in Figure 2. The inlet flow rate to Cr2 dropped, after the vessel had already been operating close to steady state.

The stabilizing control layer included level control for Cr2 and for D1 (Figure 2a–d). The controlled variable close to the disturbance, the level of Cr2, was not tightly controlled, which keeps the effects of the disturbance in the throughput locally confined, and decreases the volume in Cr2 (Figure 2a), while mitigating effects downstream. The concentration of **4** that goes into the second reaction (R2) is a key intermediate CMA and is adjusted in the quality control layer. The solvent flow rate going into D1 follows the throughput disturbances passing through W1 more aggressively, and reaches a minimum slightly after the outlet flow rate of Cr2 reaches a minimum (Figure 2b and f). As a result, the concentration of **4** in D1 does not show large variations (Figure 2e), which ensures a minimal effect of the disturbance on the performance of R2. Illustrations of the long-term automated control of CMAs are provided in the Supporting Information (Figure S6).

The second reaction is an acid-catalyzed removal of the Boc protecting group (Boc = *tert*-butoxycarbonyl). This is carried out in a tubular reactor (R2), where concentrated HCl is mixed with the slurry of **4** in ethyl acetate. Control of the concentration of **4** is necessary to maintain the appropriate equivalents of acid (16 equiv) in the reactor. Mixing is ensured by CO₂ formation in the reactor. The reaction is rapidly quenched on-line with NaOH (25 wt%), which would result in a large increase in temperature if performed in a batch process. Under continuous flow, the temperature of the reaction mixture exiting the quench remains at around 40 °C, without any cooling beyond convection from air circulation in the enclosure over the 1.6 mm ID × 3.2 mm OD × 2.5 m length PFA tubing (ID = inner diameter, OD = outer diameter) that connects the reactor to the settling tank for liquid–liquid separation (S3).

Workup of the organic phase containing **5** requires a few steps that arise from operating the process continuously. The objective of these steps is to produce a stream of **5** (6 wt %) in ethyl acetate with less than 0.1 wt % water, starting from a solution that contains **5** (25 wt %) in ethyl acetate and has approximately 6 wt % water, after contacting the aqueous quench stream.^[22] The stream is continuously diluted with ethyl acetate, which causes NaCl (from the quench) to precipitate. Microfiltration membranes (S4) remove the solid to clarify the solution prior to measuring the concentration with an inline UV flow cell that is used to control the dilution stream. Lastly, the stream is passed through a packed column (S5) of molecular sieves to remove water. The extra steps allow one main solvent (ethyl acetate) to be used through the whole process, and isolations and solvent swaps, which would disrupt the flow of material through the process and require more challenging processes that involve the handling of solids, are avoided.

A reactive crystallization^[22] is performed to create and purify the final salt **6**. Fumaric acid is added at a slight excess (0.55 equiv of acid relative to **5**) using a feed-forward controller that is based on a second inline UV detector. The material initially forms the salt in the first MSMR vessel (Cr3) at 20 °C, and then the yield is further increased by cooling in a second MSMR vessel at –10 °C. The material is filtered and washed on a second continuous filter (W2),

similar to W1. The wet cake is diluted to a concentration of 10–15 wt% with ethyl acetate, using feedback control from a density flow cell. Before drying the crystals for formulation, we add the first excipient (SiO_2). The final crystals are needle-shaped (Figure S7) and flow poorly, which results in inconsistent tablet composition from fluctuations in the gravimetric powder feeder. Poor flowability is often solved by adding a glidant,^[23] in our case SiO_2 (2.5 wt% on a dry basis). This is typically done late in the formulation process; however, that would require metering SiO_2 at 1.15 g h^{-1} , which is well outside the capabilities of commercial powder feeders. This problem was circumvented by metering the SiO_2 in a slurry prior to drying. This process could not be integrated so easily if the traditional upstream and downstream processes were disconnected and done in separate locations.

The drying process (S6 and S7) also uses equipment that was constructed in-house. It involves two stages; the first dries the stream so that it contains less than 5 wt% solvent, by using two convection-heated drums that turn to produce a thin sheet of powder. The sheet is scraped off and broken into flakes that fall into a vacuum chamber that is periodically pumped down and opened to the vacuum-drying stage. This consists of three 6 cm ID \times 1.5 m long tubes with a rotating screw that conveys the powder. The tubes are heated at increasing temperatures (40, 60, and 75°C) to prevent trapping of solvent inside the flakes owing to the rapid heating of the outside surfaces. The material exiting the dryer contains less than 5000 ppm of ethyl acetate (Figure S8). The dried powder is loaded into a gravimetric feeder using a vacuum conveyor alongside a second feeder with 6000 Da polyethylene glycol (PEG). The two powders are metered at a mass ratio of 6/PEG = 35:65 into a twin screw extruder that continuously melts and mixes the materials at 60°C .^[24] A tablet mold is coupled to the extruder outlet and forms the mixed material into tablets with a defined geometry, which are ejected six at a time.

Tablets were produced for several periods of time during the ten day operation, for lengths of up to eight hours. Finished tablets pass several tests of product quality. The tablets have a uniform visual appearance (Figure 3a), and have a comparable size and dosage as commercial tablets. The tablets dissolve rapidly, faster than commercial tablets made of a different excipient (Figure S9), which puts them within specification for immediate release doses.^[25] Residual solvents are also within the specification limits,^[26] as no solvent is

added after drying, such as for granulation, which is commonly performed in batch processing. The API retains characteristic crystalline peaks that are seen by X-ray diffraction analysis of the final product after drying and processing through the extruder and mold (Figure S10). The tablets also pass content uniformity tests (Figure 3b; see also the Supporting Information).^[27] The product contains only one significant impurity, **7** (Scheme 2), which was kept to within specification limits^[28] (Figure 3b).

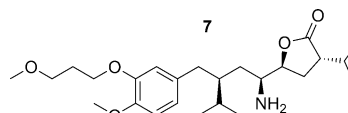

Scheme 2. Compound **7**, the main impurity in the final product.

The source of **7** present in the product can be traced back to several places in the process (Table S5), as both **1** and **5** can be converted into it. The first possibility is that unreacted **1** is carried into the second reaction where it undergoes removal of the Boc group, similar to **4**. The second possibility entails a reversible cyclization to reform the lactone from **5**, which can occur spontaneously at higher temperatures. The conditions in R1 have been optimized to increase the conversion of **1** to limit the amount of **1** entering the first crystallization and filtration steps. The crystallizations and filtration/washings are optimized to minimize the amount of impurities carried into subsequent steps that arise from temporary impurity spikes by using excess washing solvent. The three temperature zones in the vacuum dryer expose the API to high temperatures for a shorter time, once the majority of the solvent is removed. The use of PEG in the extrusion and molding reduces the temperature required to the melting point of PEG (Figure S11), instead of operating the melt extrusion at the melting point of the API.

In summary, we have developed and operated a continuous pharmaceutical plant that integrates chemical synthesis, purification, formulation, and tableting. From chemical synthesis to tableting, the entire process runs continuously. An automated control system monitors and controls the process to maintain product quality. Several new pieces of continuous equipment are used. During the design of the process, many aspects of the existing batch processes were modified to avoid difficulties with the handling of solids, and to eliminate solvent swaps. The final tablets meet specifications for drug-product quality. Future work in this area will involve developing and understanding new continuous processes, and showing their application across a range of drug products. This will be done alongside collaborations with industry and regulators to aid in translating these innovations beyond the laboratory.

Received: June 24, 2013

Published online: ■■■■■, ■■■■■

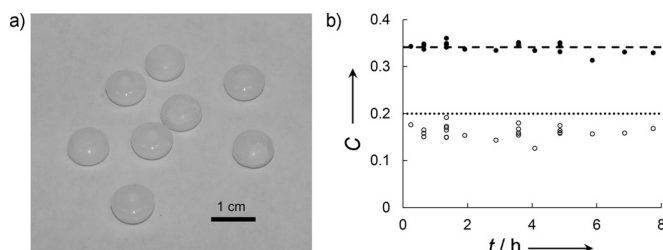

Figure 3. Analysis of tablets produced by the integrated continuous plant: a) photograph of tablets, b) tablet mass fraction of **6** (●) with the nominal concentration (0.341, ---), and % content of **7** (○) with the specification limit (0.2%,).

Keywords: continuous processing · flow chemistry · lactones · protecting groups · synthetic methods

- [1] a) J. A. DiMasi, R. W. Hansen, H. G. Grabowski, *J. Health Econ.* **2003**, *22*, 151–185; b) P. Suresh, P. Basu, *J. Pharm. Innov.* **2008**, *3*, 175–187.
- [2] a) R. A. Sheldon, *Green Chem.* **2007**, *9*, 1273–1283; b) C. Jiménez-González, P. Poehlauer, Q. B. Broxterman, B.-S. Yang, D. am Ende, J. Baird, C. Bertsch, R. E. Hannah, P. Dell’Orco, H. Noorman, S. Yee, R. Reintjens, A. Wells, V. Massonneau, J. Manley, *Org. Process Res. Dev.* **2011**, *15*, 900–911.
- [3] a) P. Poehlauer, J. Manley, R. Broxterman, B. Gregertsen, M. Ridemark, *Org. Process Res. Dev.* **2012**, *16*, 1586–1590; b) J. Evans, *Chem. Eng.* **2013**, 32–34.
- [4] a) D. M. Roberge, B. Zimmermann, F. Rainone, M. Gottsponer, M. Eyholzer, N. Kockmann, *Org. Process Res. Dev.* **2008**, *12*, 905–910; b) F. Benaskar, A. Ben-Abdelmoumen, N. Patil, E. Rebrov, J. Meuldijk, L. Hulshof, V. Hessel, U. Krtshil, J. Schouten, *J. Flow Chem.* **2011**, *1*, 74–89; c) S. D. Schaber, D. I. Gerogiorgis, R. Ramachandran, J. M. B. Evans, P. I. Barton, B. L. Trout, *Ind. Eng. Chem. Res.* **2011**, *50*, 10083–10092.
- [5] J. Jimenez in *The Future of Manufacturing in the U.S.*, Cambridge, MA, USA, **2012**.
- [6] a) H. Wu, M. A. Khan, A. S. Hussain, *Chem. Eng. Commun.* **2007**, *194*, 760–779; b) R. Lionberger, S. Lee, L. Lee, A. Raw, L. Yu, *AAPS J.* **2008**, *10*, 268–276.
- [7] a) A. E. Cervera-Padrell, T. Skovby, S. Kiil, R. Gani, K. V. Gernaey, *Eur. J. Pharm. Biopharm.* **2012**, *82*, 437–456; b) B. Benyahia, R. Lakerveld, P. I. Barton, *Ind. Eng. Chem. Res.* **2012**, *51*, 15393–15412; c) F. Boukouvala, V. Niotis, R. Ramachandran, F. J. Muzzio, M. G. Ierapetritou, *Comput. Chem. Eng.* **2012**, *42*, 30–47.
- [8] a) D. M. Roberge, L. Ducry, N. Bieler, P. Cretton, B. Zimmermann, *Chem. Eng. Technol.* **2005**, *28*, 318–323; b) J. Wegner, S. Ceylan, A. Kirschning, *Chem. Commun.* **2011**, 47, 4583–4592.
- [9] a) D. Webb, T. F. Jamison, *Chem. Sci.* **2010**, *1*, 675–680; b) R. L. Hartman, J. P. McMullen, K. F. Jensen, *Angew. Chem.* **2011**, *123*, 7642–7661; *Angew. Chem. Int. Ed.* **2011**, *50*, 7502–7519; c) L. Malet-Sanz, F. Susanne, *J. Med. Chem.* **2012**, *55*, 4062–4098; d) M. Baumann, I. R. Baxendale, S. V. Ley, N. Nikbin, C. D. Smith, J. P. Tierney, *Org. Biomol. Chem.* **2008**, *6*, 1577–1586; e) A. R. Bogdan, S. L. Poe, D. C. Kubis, S. J. Broadwater, D. T. McQuade, *Angew. Chem.* **2009**, *121*, 8699–8702; *Angew. Chem.* **2009**, *121*, 8699–8702; *Angew. Chem. Int. Ed.* **2009**, *48*, 8547–8550; f) P. Pollet, E. D. Cope, M. K. Kassner, R. Charney, S. H. Terrett, K. W. Richman, W. Dubay, J. Stringer, C. A. Eckert, C. L. Liotta, *Ind. Eng. Chem. Res.* **2009**, *48*, 7032–7036; g) K. M. Christensen, M. J. Pedersen, K. Dam-Johansen, T. L. Holm, T. Skovby, S. Kiil, *Chem. Eng. Sci.* **2012**, *71*, 111–117; h) J. Wegner, S. Ceylan, A. Kirschning, *Adv. Synth. Catal.* **2012**, *354*, 17–57.
- [10] a) H. R. Sahoo, J. G. Kralj, K. F. Jensen, *Angew. Chem.* **2007**, *119*, 5806–5810; *Angew. Chem. Int. Ed.* **2007**, *46*, 5704–5708; b) M. D. Johnson, S. A. May, J. R. Calvin, J. Remacle, J. R. Stout, W. D. Diseroad, N. Zaborenko, B. D. Haeberle, W.-M. Sun, M. T. Miller, J. Brennan, *Org. Process Res. Dev.* **2012**, *16*, 1017–1038; c) A. E. Cervera-Padrell, S. T. Morthensen, D. J. Lewandowski, T. Skovby, S. Kiil, K. V. Gernaey, *Org. Process Res. Dev.* **2012**, *16*, 888–900; d) M. O’Brien, P. Koos, D. L. Browne, S. V. Ley, *Org. Biomol. Chem.* **2012**, *10*, 7031–7036.
- [11] a) J. Chen, B. Sarma, J. M. B. Evans, A. S. Myerson, *Cryst. Growth Des.* **2011**, *11*, 887–895; b) S. Lawton, G. Steele, P. Shering, L. Zhao, I. Laird, X.-W. Ni, *Org. Process Res. Dev.* **2009**, *13*, 1357–1363; c) D. W. Griffin, D. A. Mellichamp, M. F. Doherty, *Chem. Eng. Sci.* **2010**, *65*, 5770–5780; d) R. J. P. Eder, E. K. Schmitt, J. Grill, S. Radl, H. Gruber-Woelfler, J. G. Khinast, *Cryst. Res. Technol.* **2011**, *46*, 227–237; e) S. Y. Wong, A. P. Tatusko, B. L. Trout, A. S. Myerson, *Cryst. Growth Des.* **2012**, *12*, 5701–5707.
- [12] a) Y. Gonniissen, S. I. V. Gonçalves, B. G. De Geest, J. P. Remon, C. Vervaet, *Eur. J. Pharm. Biopharm.* **2008**, *68*, 760–770; b) M. Wang, G. C. Rutledge, A. S. Myerson, B. L. Trout, *J. Pharm. Sci.* **2012**, *101*, 1178–1188; c) B. Brettmann, K. Cheng, A. Myerson, B. Trout, *Pharm. Res.* **2013**, *30*, 238–246.
- [13] a) L. Pernenkil, C. L. Cooney, *Chem. Eng. Sci.* **2006**, *61*, 720–742; b) P. M. Portillo, M. G. Ierapetritou, F. J. Muzzio, *Powder Technol.* **2008**, *182*, 368–378; c) A. Dubey, A. U. Vanarase, F. J. Muzzio, *AIChE J.* **2012**, *58*, 3676–3684; d) K. Järvinen, W. Hoehe, M. Järvinen, S. Poutiainen, M. Juuti, S. Borchert, *Eur. J. Pharm. Sci.* **2013**, *48*, 680–688.
- [14] a) E. I. Keleb, A. Vermeire, C. Vervaet, J. P. Remon, *Eur. J. Pharm. Biopharm.* **2001**, *52*, 359–368; b) D. Djuric, B. Van Melkebeke, P. Kleinebudde, J. P. Remon, C. Vervaet, *Eur. J. Pharm. Biopharm.* **2009**, *71*, 155–160; c) R. Singh, M. Ierapetritou, R. Ramachandran, *Int. J. Pharm.* **2012**, *438*, 307–326.
- [15] M. Sen, A. Chaudhury, R. Singh, J. John, R. Ramachandran, *Int. J. Pharm.* **2013**, *445*, 29–38.
- [16] Based on the process used by Novartis.
- [17] M. A. Foley, T. F. Jamison, *Org. Process Res. Dev.* **2010**, *14*, 1177–1181.
- [18] a) H. Rüeger, S. Stutz, R. Göschke, F. Spindler, J. Maibaum, *Tetrahedron Lett.* **2000**, *41*, 10085–10089; b) D. A. Sandham, R. J. Taylor, J. S. Carey, A. Fässler, *Tetrahedron Lett.* **2000**, *41*, 10091–10094; c) A. Dondoni, G. De Lathauwer, D. Perrone, *Tetrahedron Lett.* **2001**, *42*, 4819–4823; d) S. Hanessian, S. Guesné, E. Chénard, *Org. Lett.* **2010**, *12*, 1816–1819.
- [19] J. G. Kralj, H. R. Sahoo, K. F. Jensen, *Lab Chip* **2007**, *7*, 256–263.
- [20] H. Zhang, J. Quon, A. J. Alvarez, J. Evans, A. S. Myerson, B. Trout, *Org. Process Res. Dev.* **2012**, *16*, 915–924.
- [21] R. Lakerveld, B. Benyahia, R. D. Braatz, P. I. Barton, *AIChE J.* **2013**, DOI: 10.1002/aic.14107.
- [22] J. L. Quon, H. Zhang, A. Alvarez, J. Evans, A. S. Myerson, B. L. Trout, *Cryst. Growth Des.* **2012**, *12*, 3036–3044.
- [23] G. Gold, R. N. Duvall, B. T. Palermo, J. G. Slater, *J. Pharm. Sci.* **1966**, *55*, 1291–1295.
- [24] a) E. R. Bell, Ph.D. thesis, MIT (USA), **2011**; b) J. Breitenbach, *Eur. J. Pharm. Biopharm.* **2002**, *54*, 107–117.
- [25] United States Pharmacopeial (711), 1 December 2011.
- [26] International Conference on Harmonization Q3C (R5), 4 February 2011.
- [27] United States Pharmacopeial (905), 1 December 2011.
- [28] International Conference on Harmonization Q3B (R2), 2 June 2006.

Communications



Continuous Drug Manufacturing

S. Mascia, P. L. Heider, H. Zhang,
R. Lakerveld, B. Benyahia, P. I. Barton,
R. D. Braatz, C. L. Cooney, J. M. B. Evans,
T. F. Jamison, K. F. Jensen, A. S. Myerson,
B. L. Trout* ————— ■■■■-■■■■

End-to-End Continuous Manufacturing of
Pharmaceuticals: Integrated Synthesis,
Purification, and Final Dosage Formation

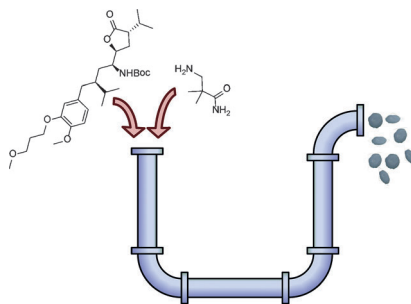

A series of tubes: The continuous manufacture of a finished drug product starting from chemical intermediates is reported. The continuous pilot-scale plant used a novel route that incorporated many advantages of continuous-flow processes to produce active pharmaceutical ingredients and the drug product in one integrated system.